

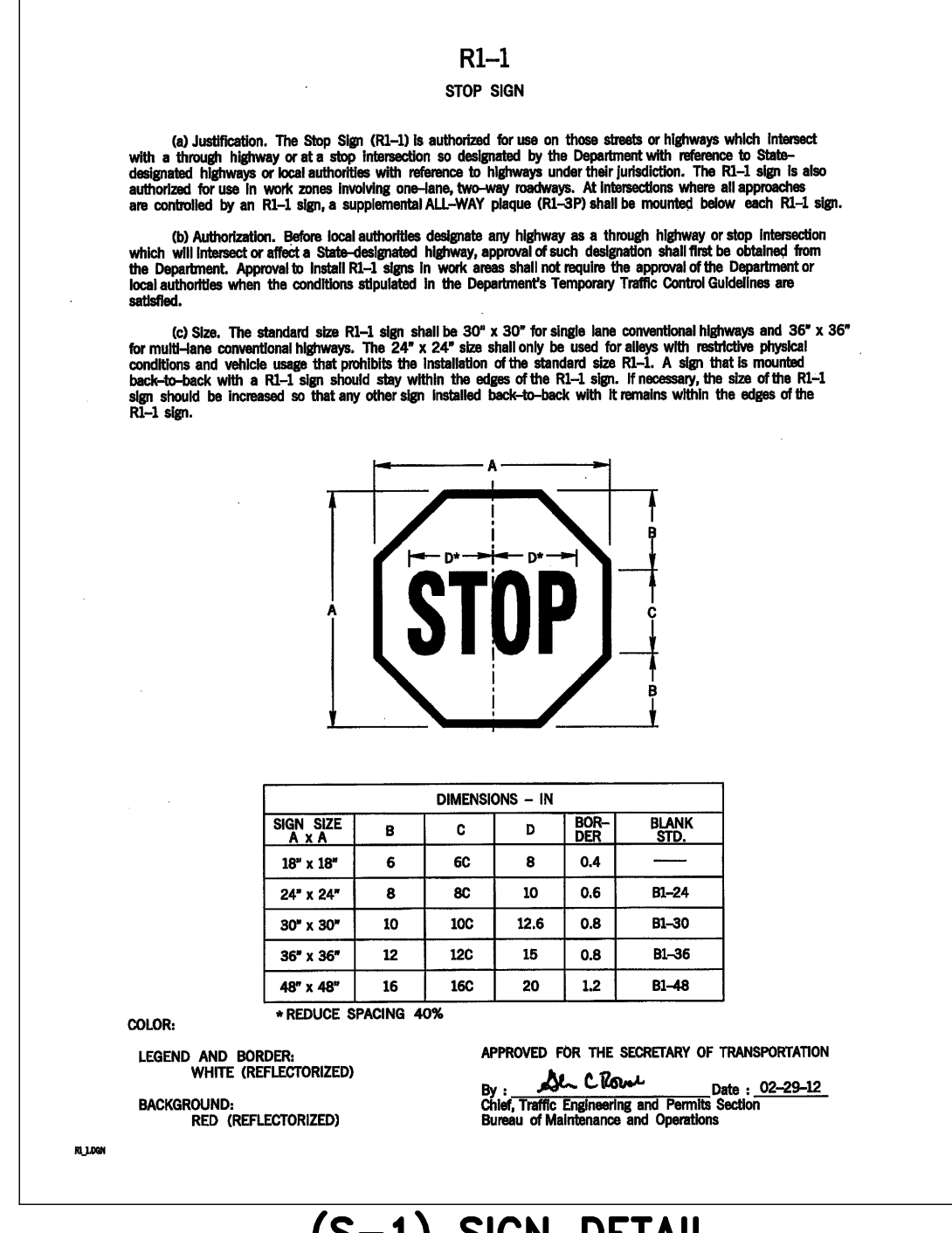

DLHowell

Civil Engineering
Land Planning
Environmental
www.DLHowell.com

1250 Wrights Lane
West Chester, PA 19380
Phone: (610) 918-9002
Fax: (610) 918-9003

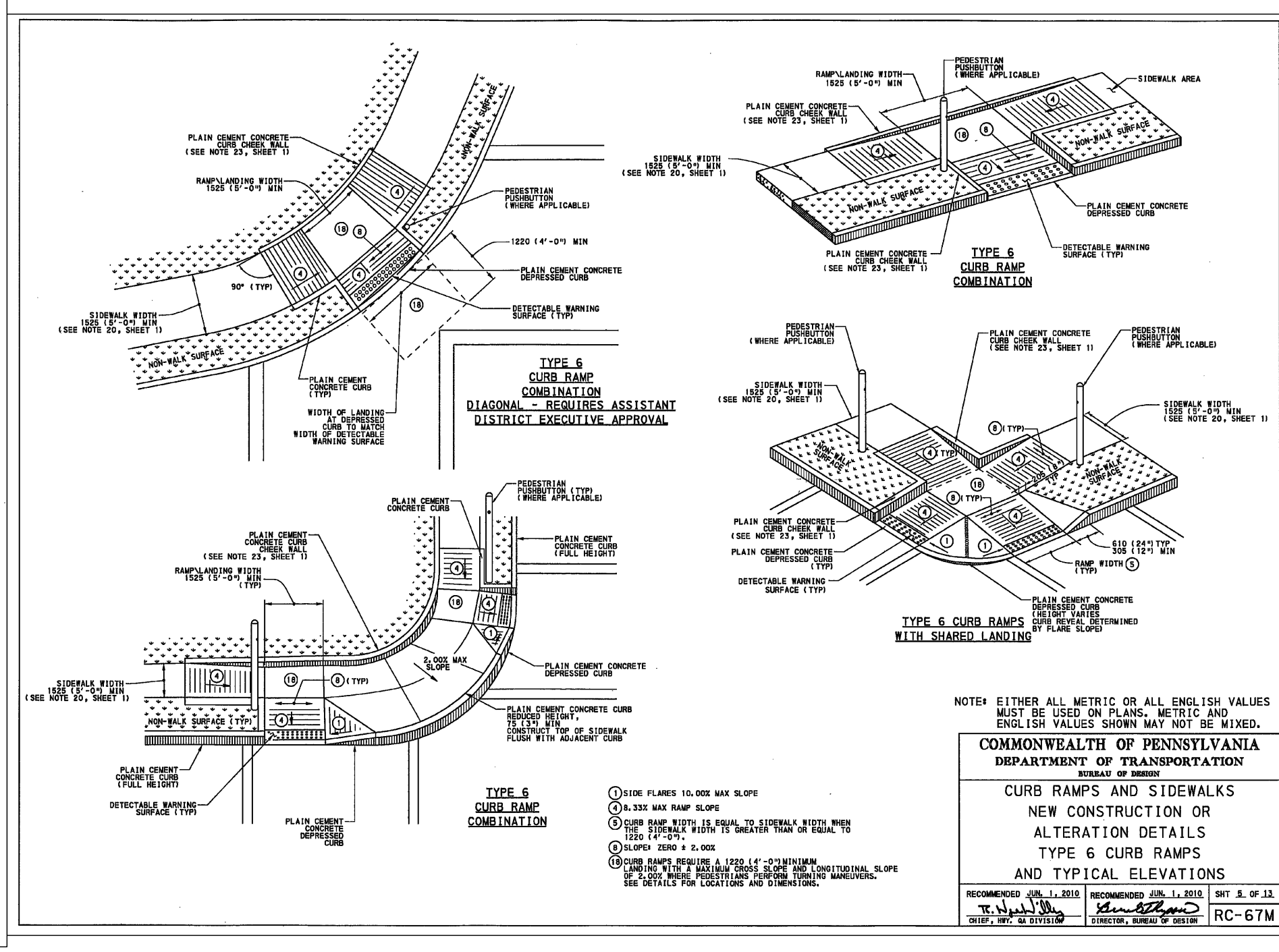
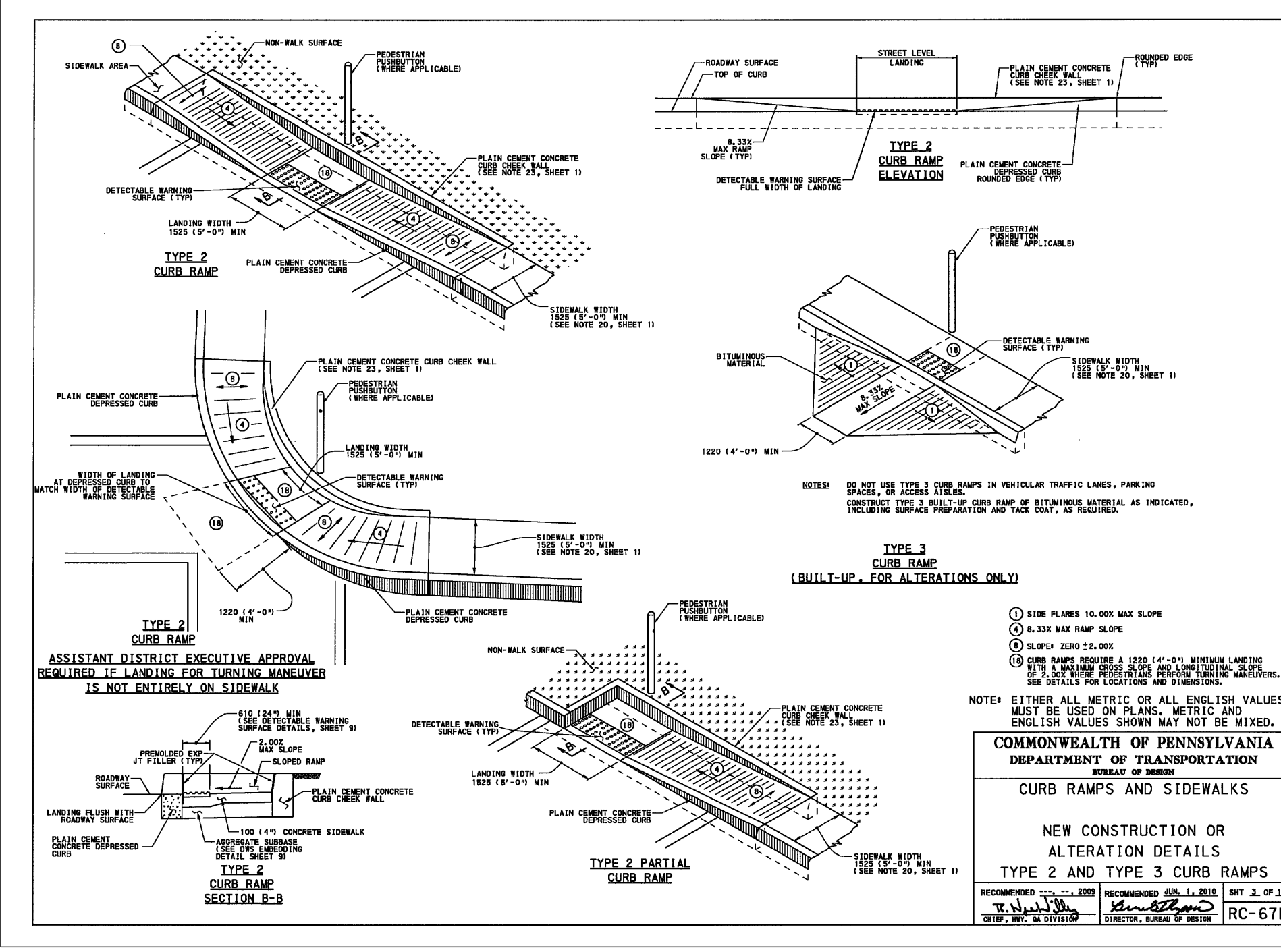

(S-1) SIGN DETAIL
NOT TO SCALE

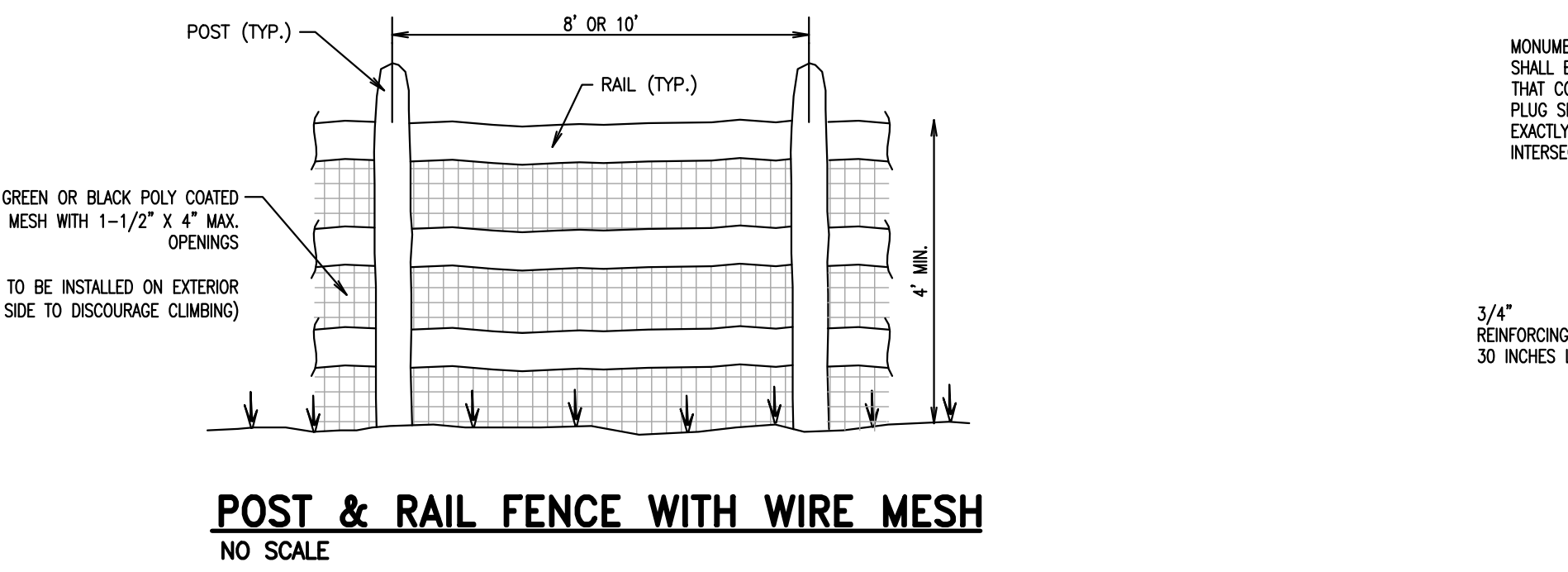

POST & RAIL FENCE WITH WIRE MESH
NO SCALE

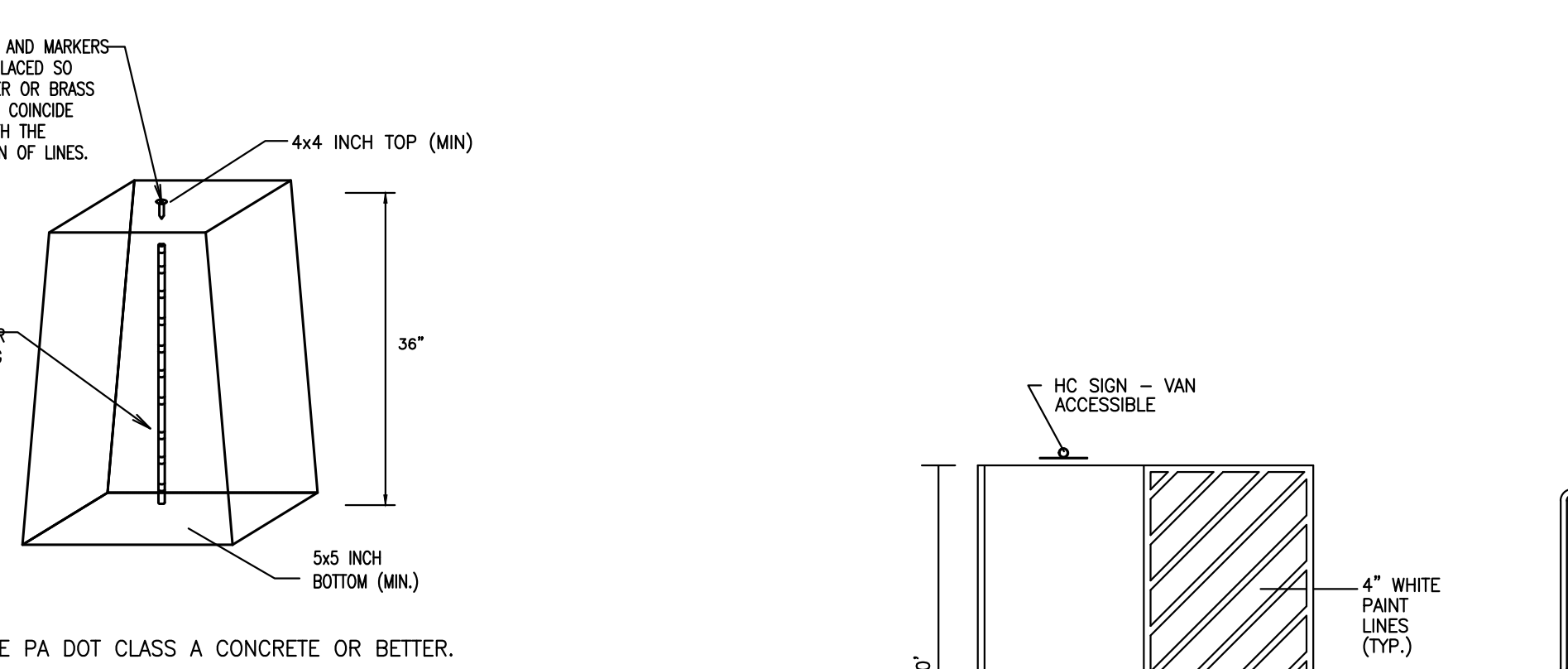

CONCRETE MONUMENT DETAIL
NOT TO SCALE

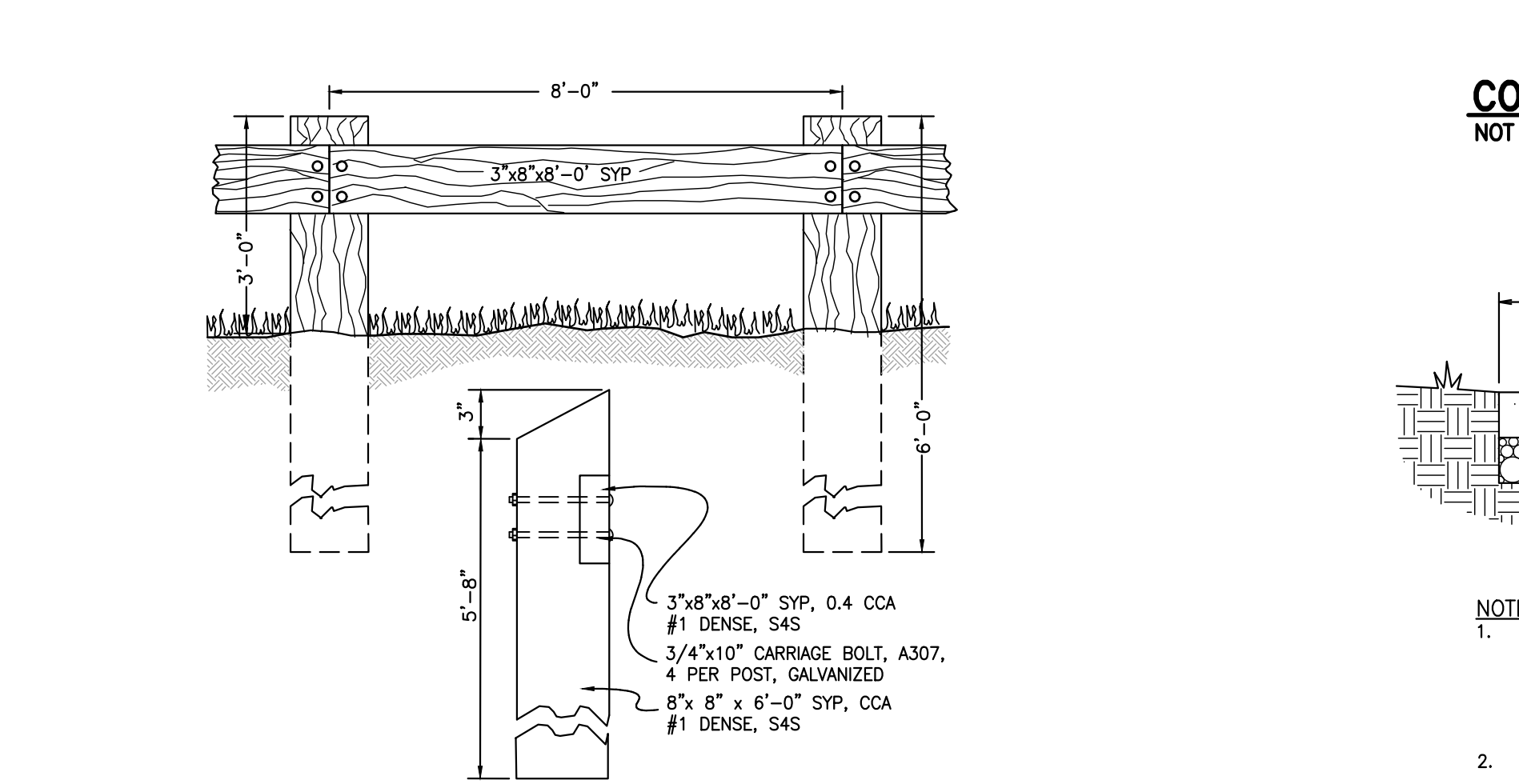

WOODEN GUIDE RAIL & POST DETAIL
NO SCALE

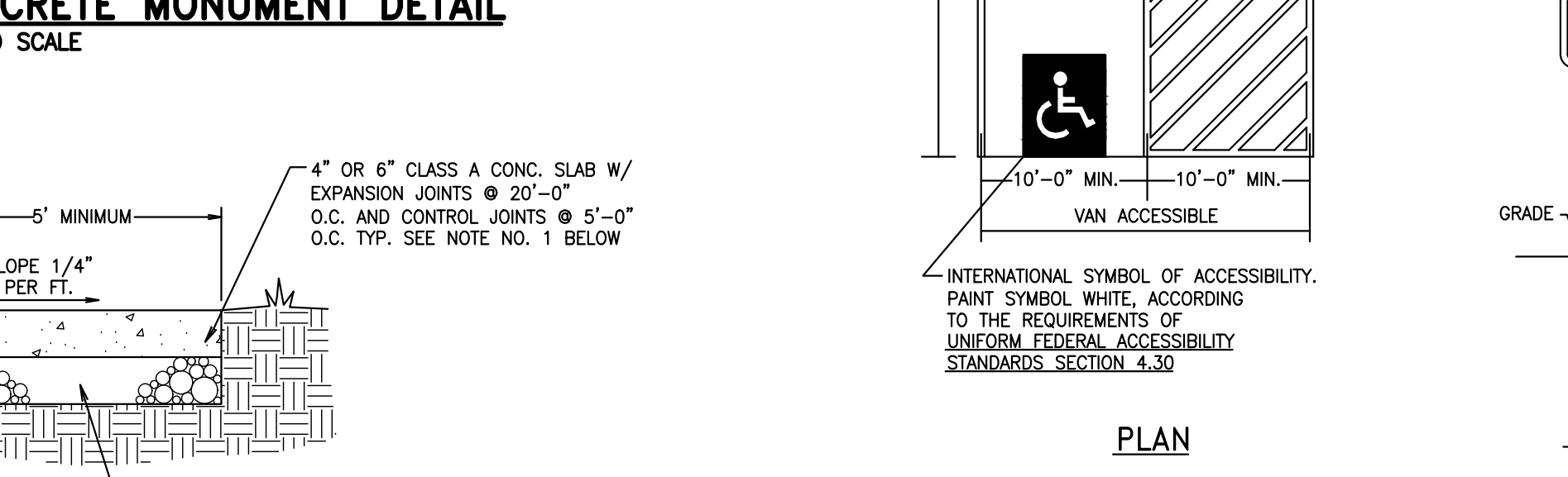

HANDICAP ACCESSIBILITY FACILITIES
NOT TO SCALE



SIDEWALK DETAIL
NOT TO SCALE

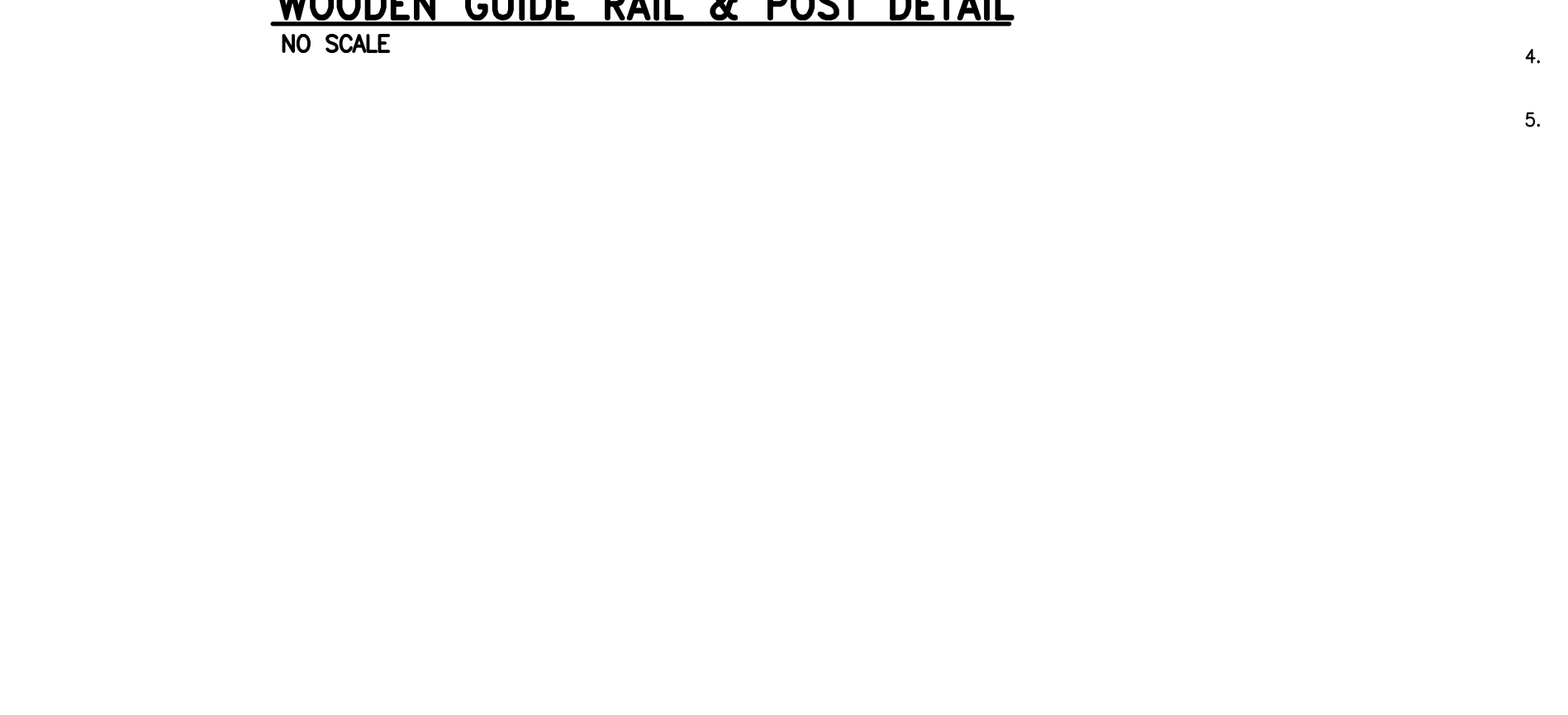

TYPICAL CROSSWALK STRIPING DETAIL
NOT TO SCALE



PAVEMENT STRIPING DETAIL
NOT TO SCALE



PAINTED STOP BAR DETAIL
NOT TO SCALE



CURB TAPER DETAIL
NOT TO SCALE

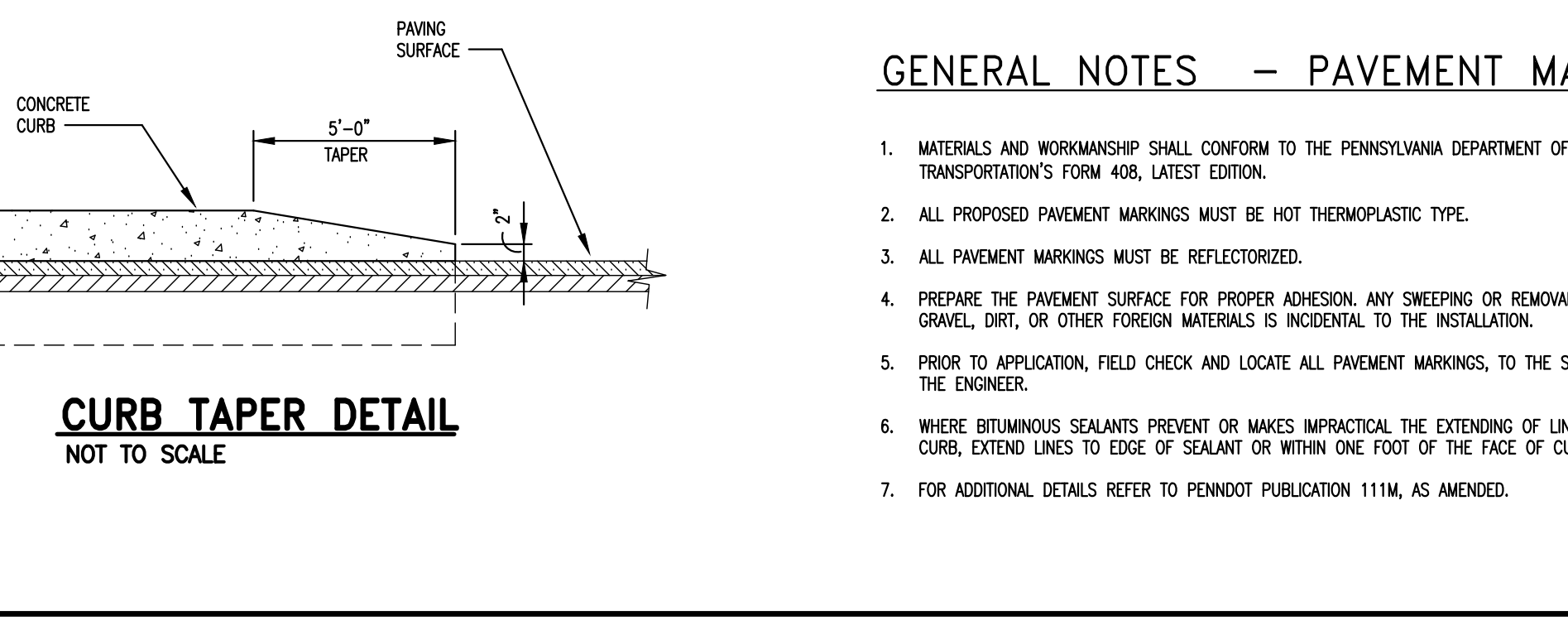

GENERAL NOTES - PAVEMENT MARKING

- 1. MATERIALS AND WORKMANSHIP SHALL CONFORM TO THE PENNSYLVANIA DEPARTMENT OF TRANSPORTATION'S FORM 408, LATEST EDITION.
2. ALL PROPOSED PAVEMENT MARKINGS MUST BE HOT THERMOPLASTIC TYPE.
3. ALL PAVEMENT MARKINGS MUST BE REFLECTORIZED.
4. PREPARE THE PAVEMENT SURFACE FOR PROPER ADHESION, ANY SWEEPING OR REMOVAL OF DEBRIS, GRAVEL, DIRT, OR OTHER FOREIGN MATERIALS IS INCIDENTAL TO THE INSTALLATION.
5. PRIOR TO APPLICATION, FIELD CHECK AND LOCATE ALL PAVEMENT MARKINGS, TO THE SATISFACTION OF THE ENGINEER.
6. WHERE BITUMINOUS SEALANTS PREVENT OR MAKE IMPRACTICAL THE EXTENDING OF LINES TO FACE OF CURB, EXTEND LINES TO EDGE OF SEALANT OR WITHIN ONE FOOT OF THE FACE OF CURB.
7. FOR ADDITIONAL DETAILS REFER TO PENNDOT PUBLICATION 111M, AS AMENDED.

8" CURBING & PAVING SECTION
NOT TO SCALE

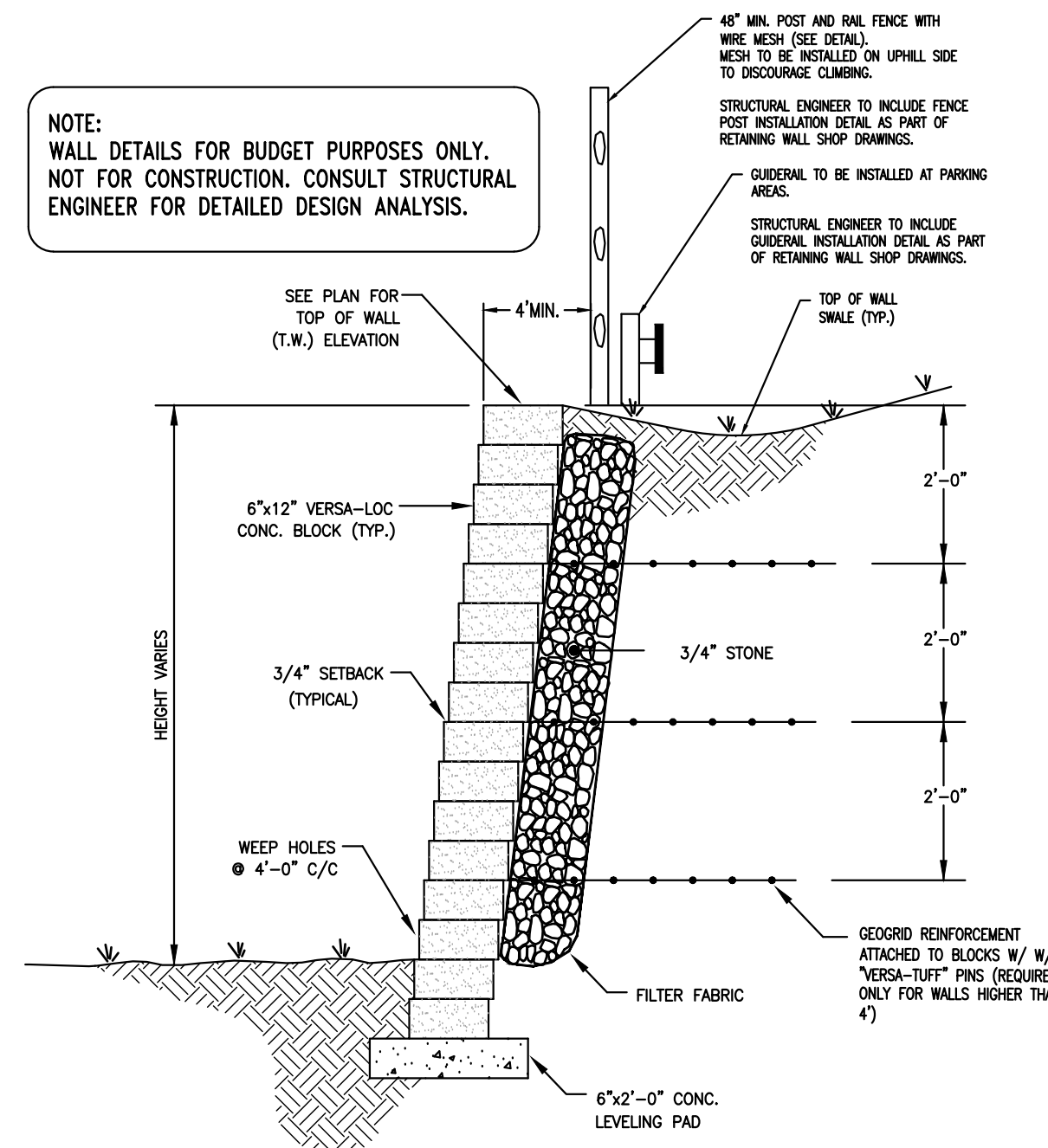

CONCEPTUAL INTERLOCKING CONCRETE BLOCK WALL
NOT TO SCALE

NOTE: RETAINING WALLS ARE SUBJECT TO TOWNSHIP ENGINEER REVIEW AND APPROVAL. DETAILED SHOP DRAWINGS, SIGNED AND SEALED BY A REGISTERED PROFESSIONAL ENGINEER LICENSED IN THE COMMONWEALTH OF PENNSYLVANIA, SHALL BE SUBMITTED TO THE TOWNSHIP FOR APPROVAL PRIOR TO CONSTRUCTION. SHOP DRAWINGS WILL ADDRESS SETTLEMENT POTENTIAL.

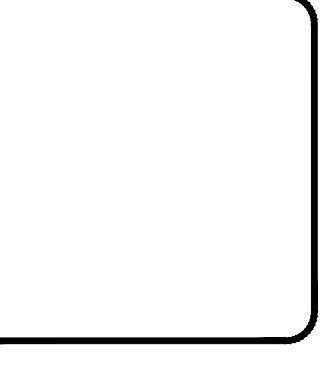
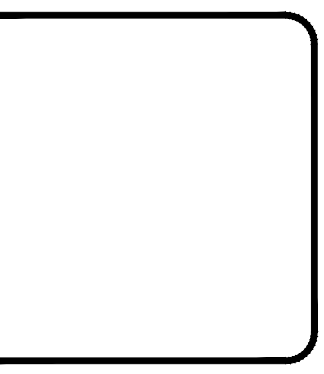

Table with 10 columns and 1 row, likely a revision or schedule table.

PRELIMINARY CONSTRUCTION DETAILS

CLIENT: MITCHELL HOMES
PROJECT: SMITH PROPERTY
LOCATION: 548 ROSDALE ROAD
KENNETT TOWNSHIP, CHESTER COUNTY, PA

DATE: 04/30/19
SCALE: N.T.S.
DRAWN BY: JTE
CHECKED BY: JWB
PROJECT NO.: 3388
C/D FILE: PROFILE SHEET.dwg
PLOTTED: 04/30/19
DRAWING NO.: C08.1
SHEET 23 OF 27